

PRESIDENT'S REPORT

August 12, 2009



CHICAGO TRANSIT AUTHORITY

Budget/Furloughs

- Funding losses
- Cost control
- Fiscal discipline
- Deferring pay raises
- Furloughs

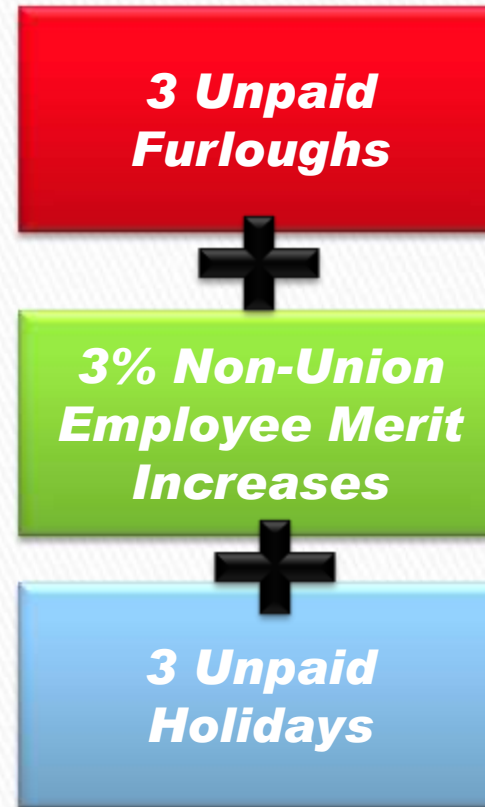

\$2.9M savings



Unauthorized Radio Transmitter



Message

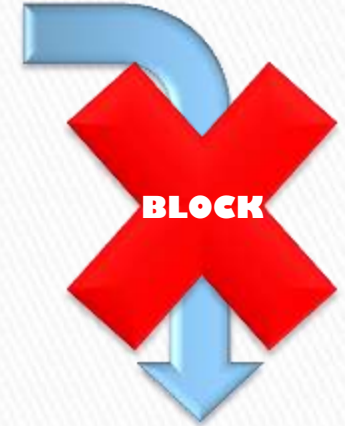

Key CTA Personnel

Operations
Control Center
Safety and Security



Investigative Partners

Joint Terrorism Task Force - OEMC - CPD - FBI - FCC

Personal Electronic Device Policy

• Zero Tolerance Policy

- Cell phones
- MP3 players
- PDAs
- Ear pieces
- DVD players
- Portable video games



CTA to fire employees caught using cell phones on duty

New policy also applies to other personal electronic devices

No texting, no phones for CTA rail workers

Zero-tolerance policy bans personal electronic devices while they're on the job



Deep Clean Initiative

CURRENT STATE



FUTURE STATE

- Expanded, professionalized inspection process
- Coordination to deliver customer facing results
- Dedicated cleaning and auditing schedule
- Results-oriented efforts
- Established baseline

Employee Development Program

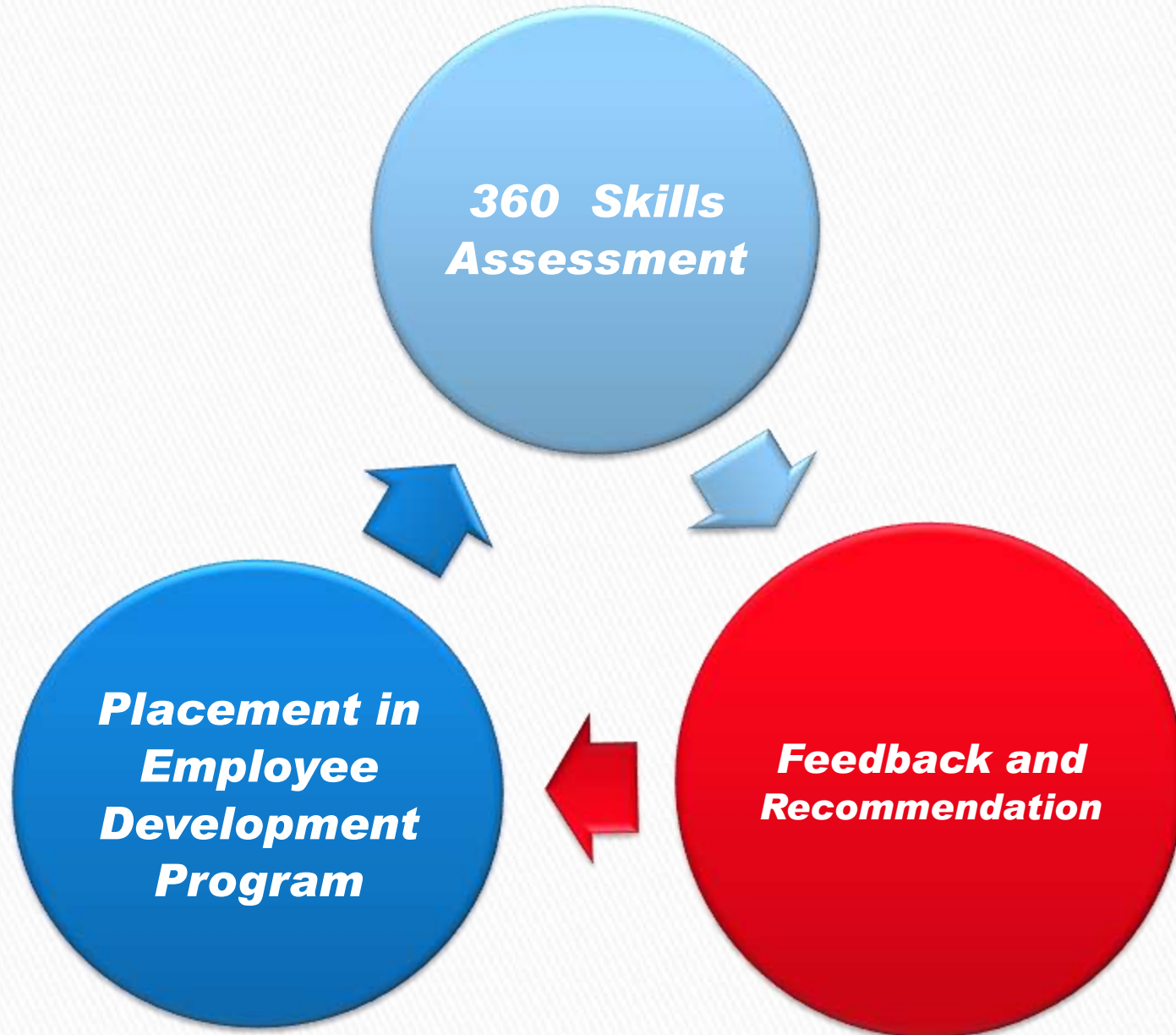

New Time and Attendance Solution

- Make better use of existing data and reduce paperwork

Enterprise Resource Planning System

Time & Attendance Solution with Business Intelligence

Biometric Reader

Existing Systems

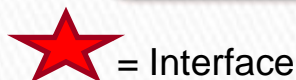



RIDERSHIP REPORT

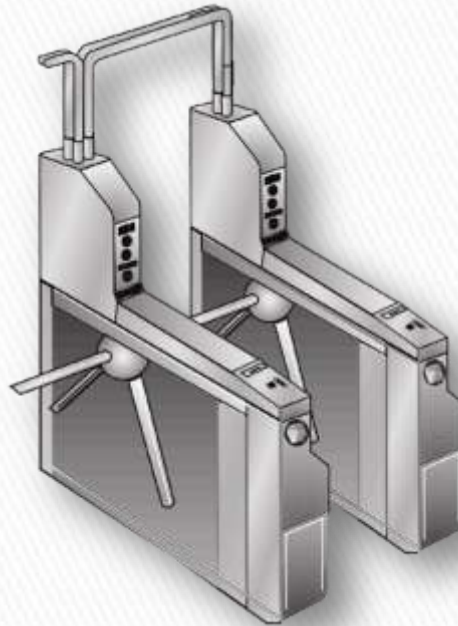

July 2009 Ridership

- 44.8 million rides provided

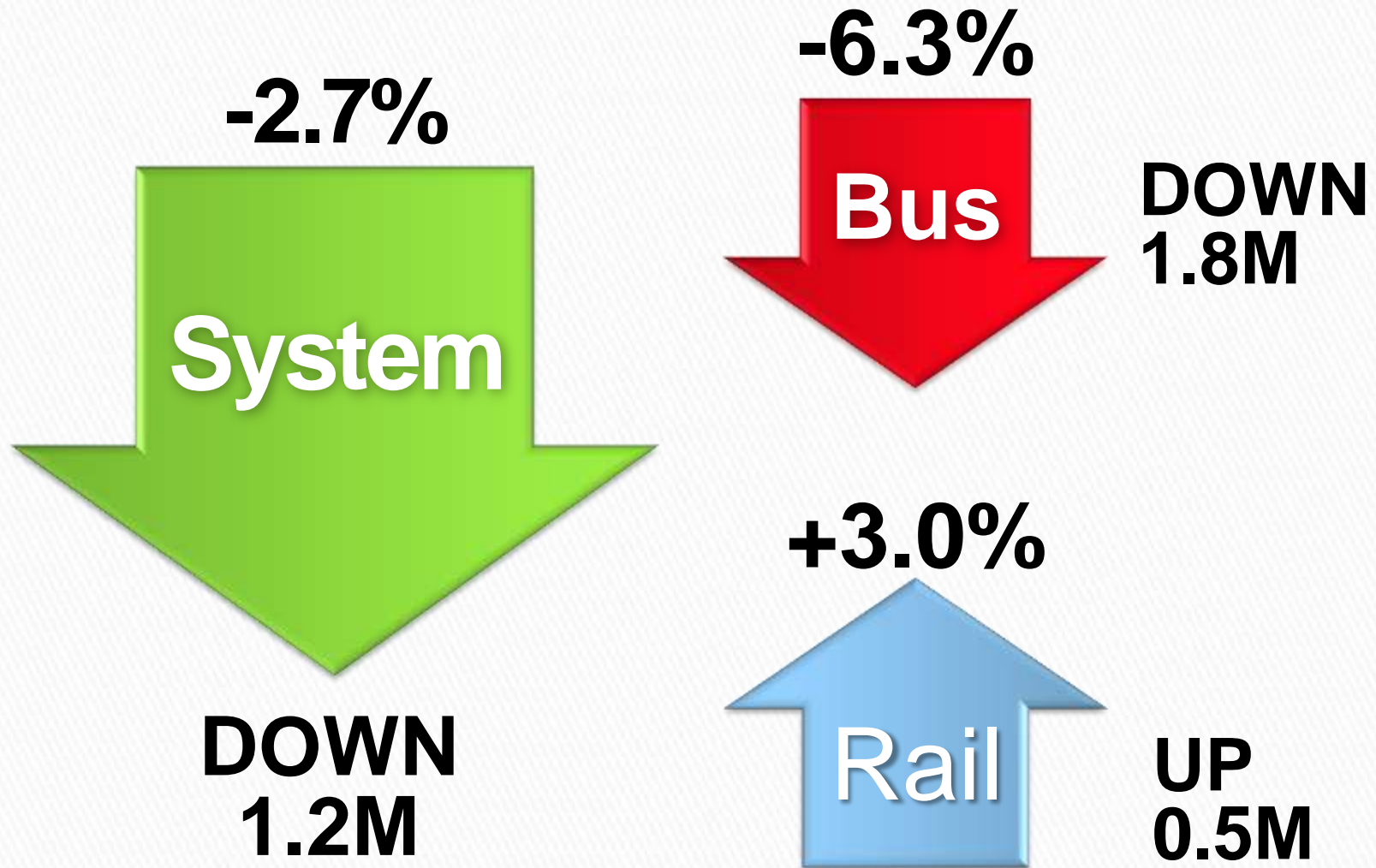

• Change and Percent Change data are adjusted for calendar differences.

Month-by-Month Ridership, 2007- 2009

- Ridership still outperforming 2007

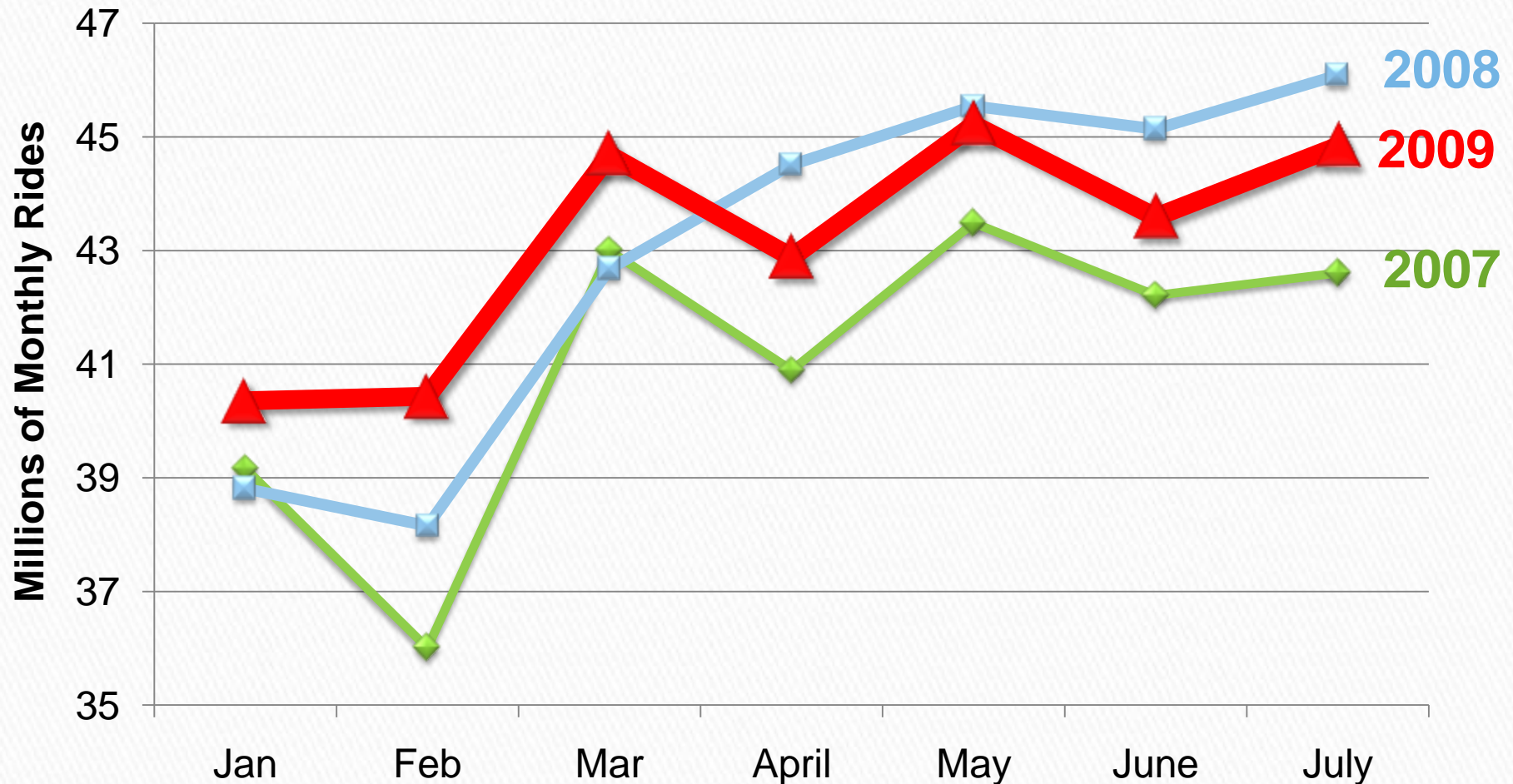

• Data are adjusted to account for calendar differences.

July Ridership, Change by Time Period

- Loss of commuters hurting rush hour

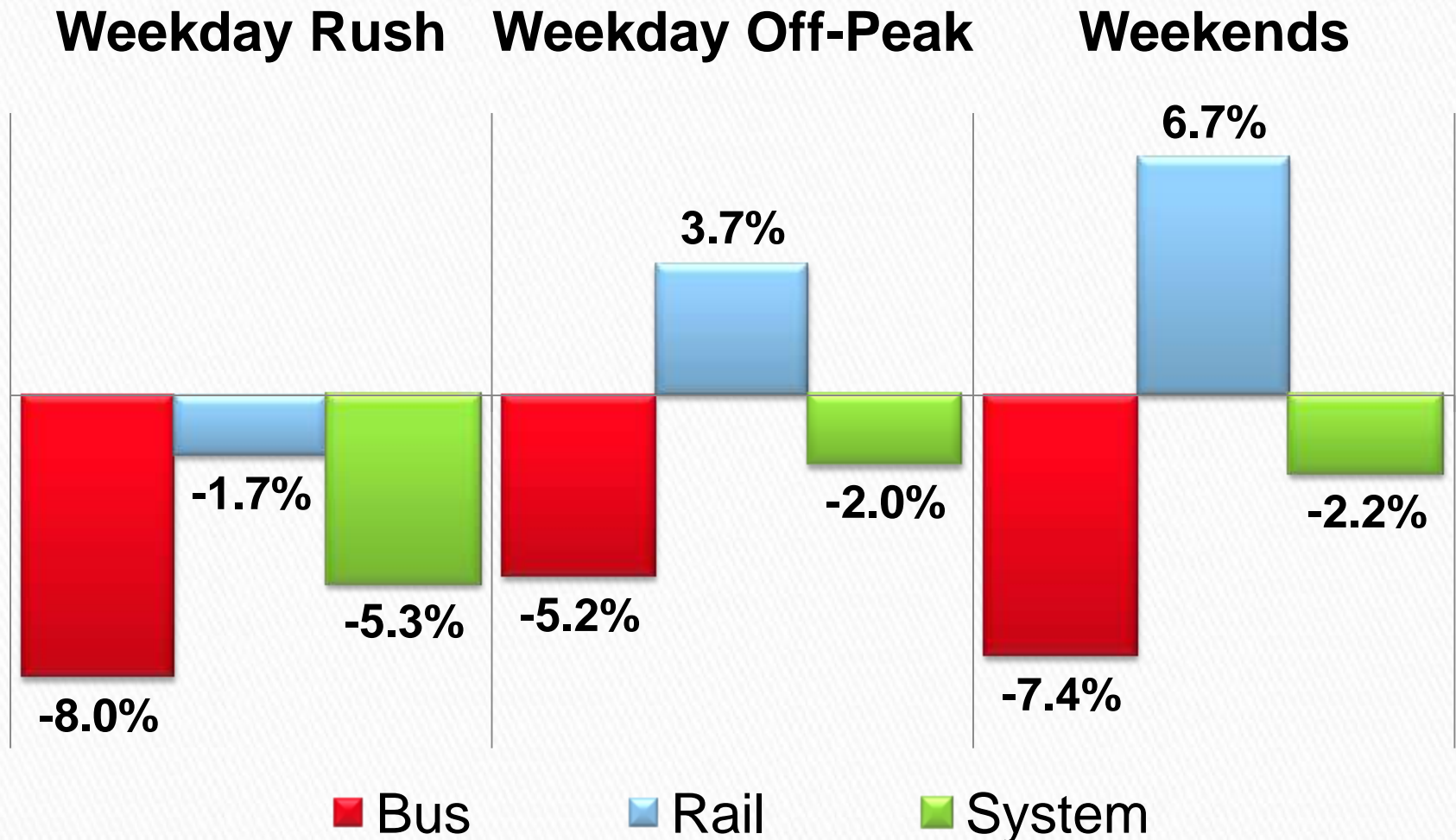

Ridership Changes by Geography

- **Down in the majority of the service area**

- South and West-Northwest sides are the most deeply impacted
- North side along the rail system is only significant growth zone
- Blue Line, Rosemont to O'Hare, was closed for 2 weeks in July 2008

CHANGE IN WEEKDAY RIDERSHIP
BUS/RAIL COMBINED
July 2009 vs. July 2008

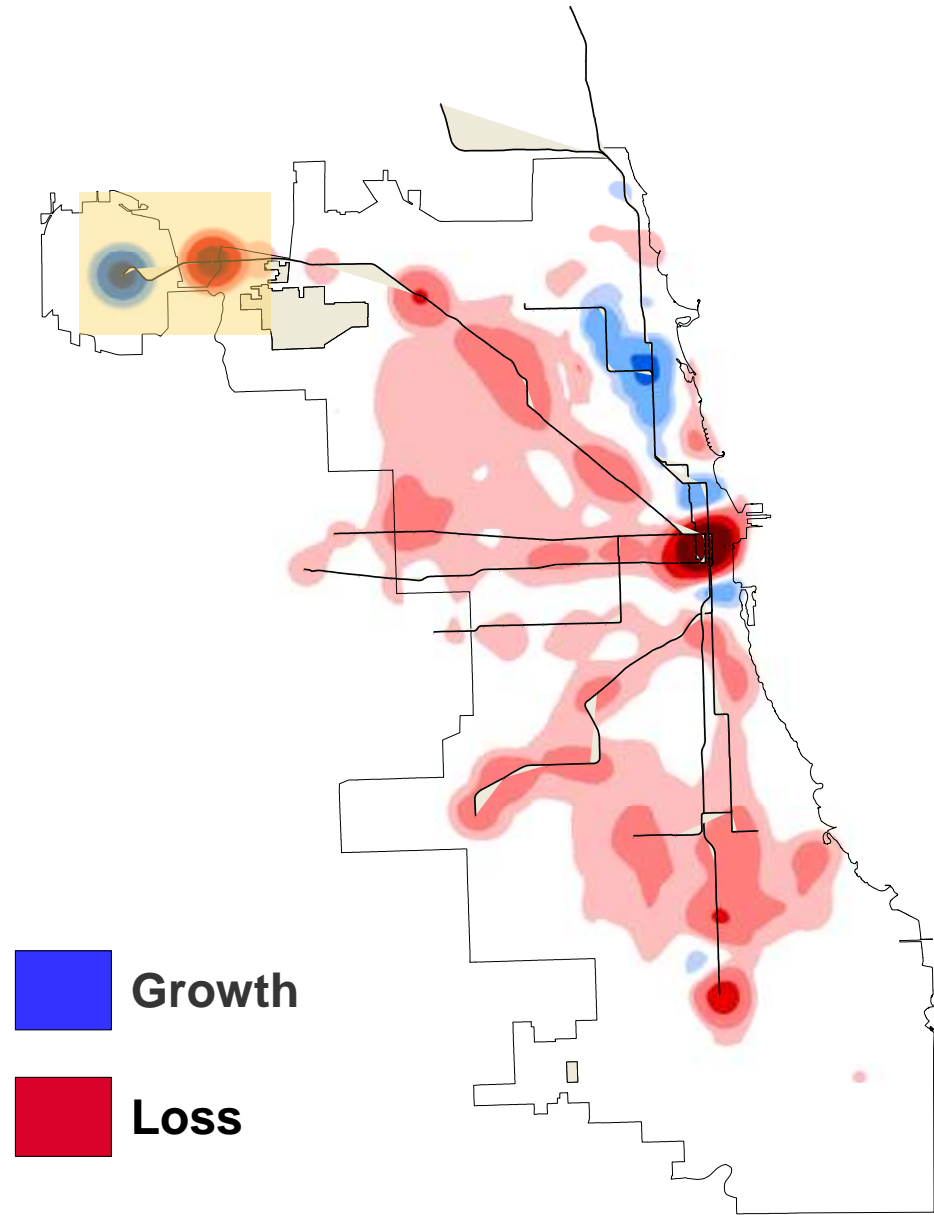

Year-to-Date Ridership, Through July

- Ridership continues to be positive

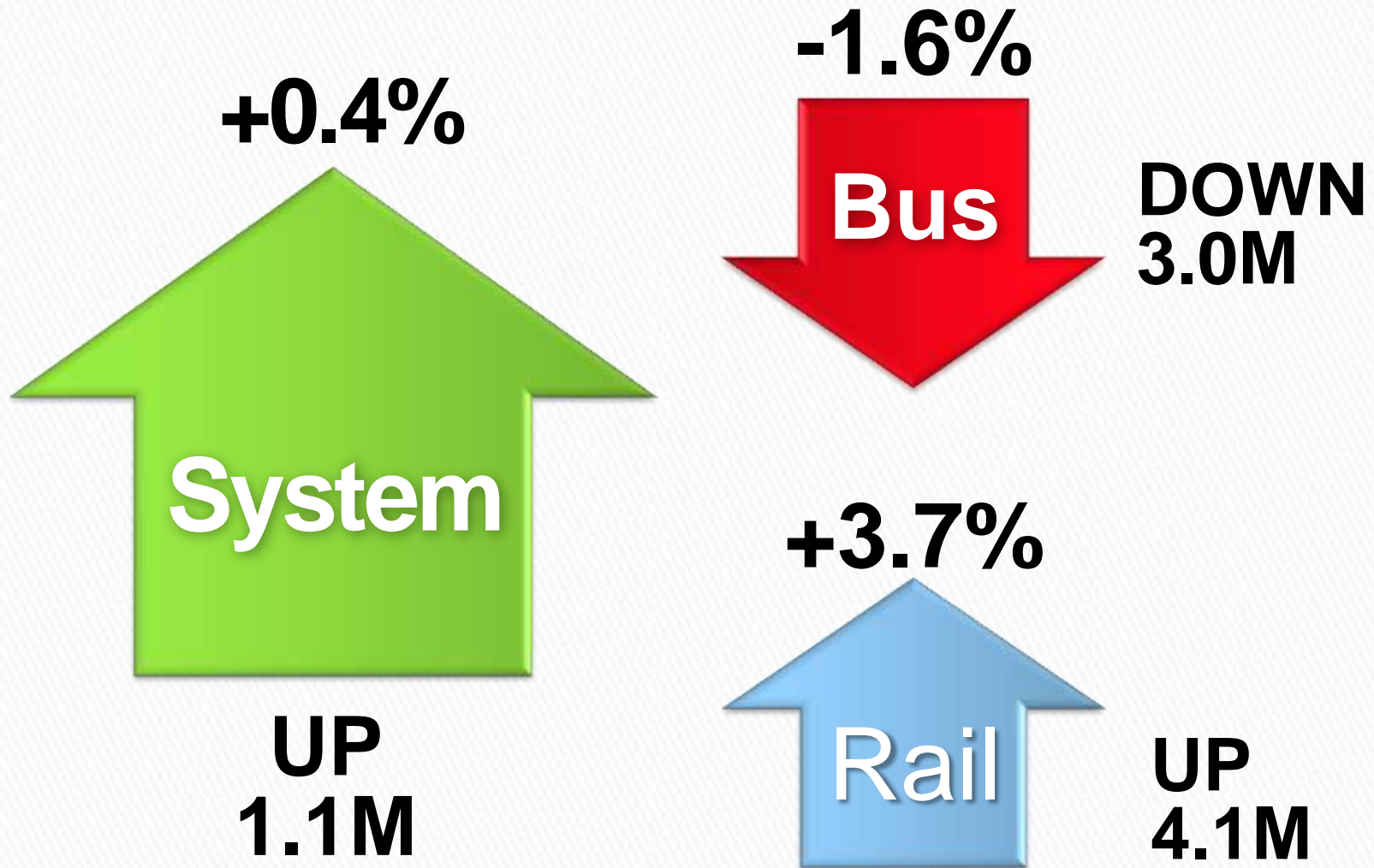

• Change and Percent Change data are adjusted for calendar differences.